

CA-1000 CONFIGURABLE CONNECTOR ACCESSORY ENCLOSURE

This guide describes how to install the internal accessory, internal cable, cable adapter, I/O panelettes, filler panels, external cables, and the optional rack-mount and stack-mount kits with your Configurable Connector Accessory (CA-1000) enclosure.

Introduction

The CA-1000 is a multipurpose data acquisition (DAQ) accessory enclosure designed to optimize user-defined input/output (I/O) connectivity and flexibility. The CA-1000 is a portable enclosure for laptop, desktop, and rack-mount applications. You can install many National Instruments DAQ products in the CA-1000 including:

- SC-204 x and SC-207 x signal conditioning products
- CB-50LP, CB-68LPR, and SCB-68 connector blocks

The CA-1000 combined with any of these products produces compact, portable, flexible, and comprehensive signal conditioning interconnection systems. The CA-1000 allows you to quickly connect and disconnect standard I/O connectors for quick system integration and reconfiguration.

The external dimensions of the CA-1000 allow you to place a laptop computer directly on its top. In desktop applications, you can use a single CA-1000 enclosure or stack multiple enclosures using the optional CA-1000 stack-mount kit. An optional CA-1000 rack-mount kit is available for standard 19 in. rack-mount applications.

What You Need to Get Started

You need the following items to set up and use your CA-1000 enclosure:

- CA-1000 Configurable Connector Accessory Enclosure Installation Guide*
- CA-1000 enclosure
- CA-1000 hardware
 - Panelette label sheet
 - Rubber feet kit
 - Four rubber feet
 - Four 4-40 panhead shoulder screws with 0.08 in. shoulder length and 0.125 in. thread length
 - Filler panel and standoff kit
 - Four black blank filler panels
 - Two silver 68-pin filler panels
 - Ten 4-40 × 3/16 in. black flathead screws
 - Four 4-40 × 1/2 in. female to female nylon standoffs
- National Instruments supplied screwdriver
- Rack-mount kit (optional)
- Stack-mount kit (optional)
- One of the following internal accessories:
 - SC-2040
 - SC-2042-RTD
 - SC-2043-SG
 - SC-2070
 - SC-2071
 - SC-2072
 - CB-50LP



Note The above internal accessories require an R50M-50F ribbon cable to make a 50-pin external connection. They require a 68M-50F MIO Bulkhead Ribbon Cable to make a 68-pin external connection.

- CB-68LPR
- SCB-68



Note The CB-68LPR and SCB-68 attach directly to the wall of the enclosure. The SCB-68 accommodates only a 68-pin external connection through the rear of the enclosure.

You must remove the SCB-68 circuit board from its original enclosure before installing it in the CA-1000 enclosure.

- One or more I/O panelettes

You do not need to configure your CA-1000 enclosure or its components other than to decide where to put your signal connections (both input and output in some cases). To configure your internal accessory, see the manual for that accessory.

Installing the CA-1000 Components

The CA-1000 system consists of four components:

- CA-1000 enclosure
- Internal accessory
- Internal cable assembly (not required for all internal accessories)
- I/O panelettes

By choosing a specific combination of components, you can customize the CA-1000 for many applications.

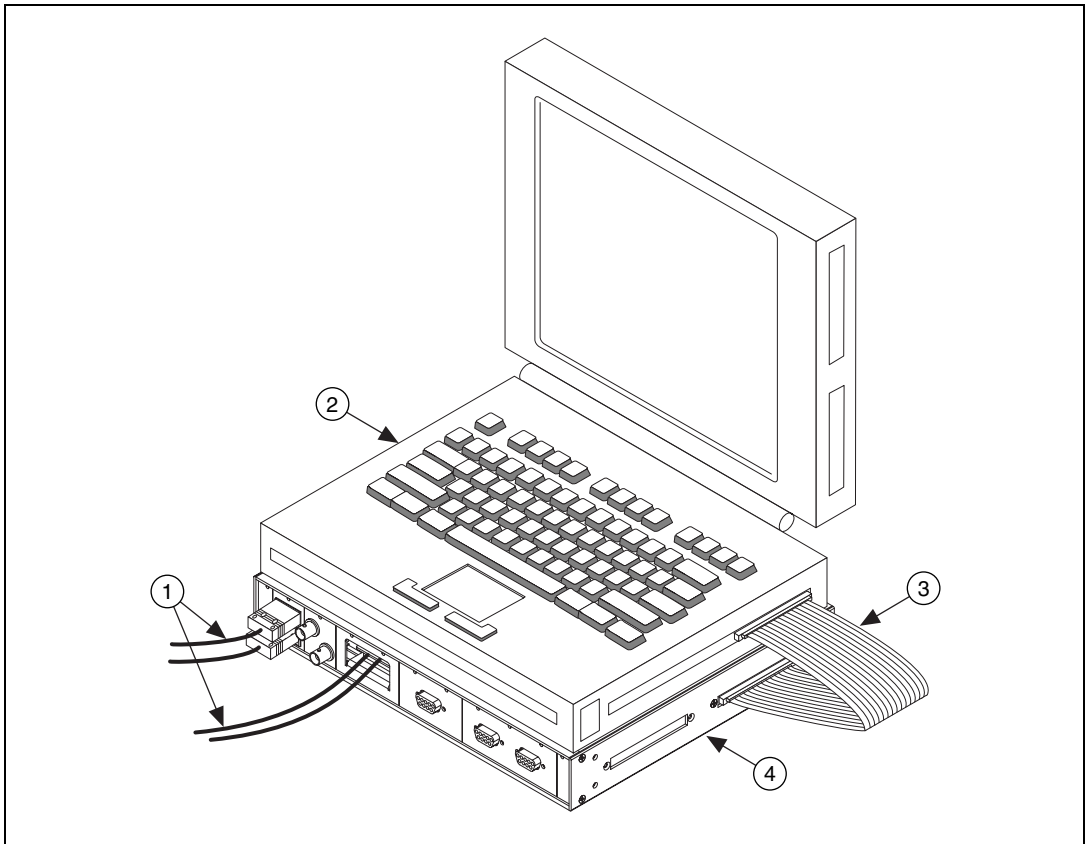

1 Signals to Applications
2 Laptop Computer

3 External Cable
4 CA-1000 Enclosure

Figure 1. Typical CA-1000 Laptop Configuration

Refer to Figure 2 and use the following steps to open the CA-1000 enclosure:

1. Remove the eight 4-40 \times 1/4 in. flathead Phillips-head screws from the top cover.
2. Remove the top cover.

You are ready to install your components.

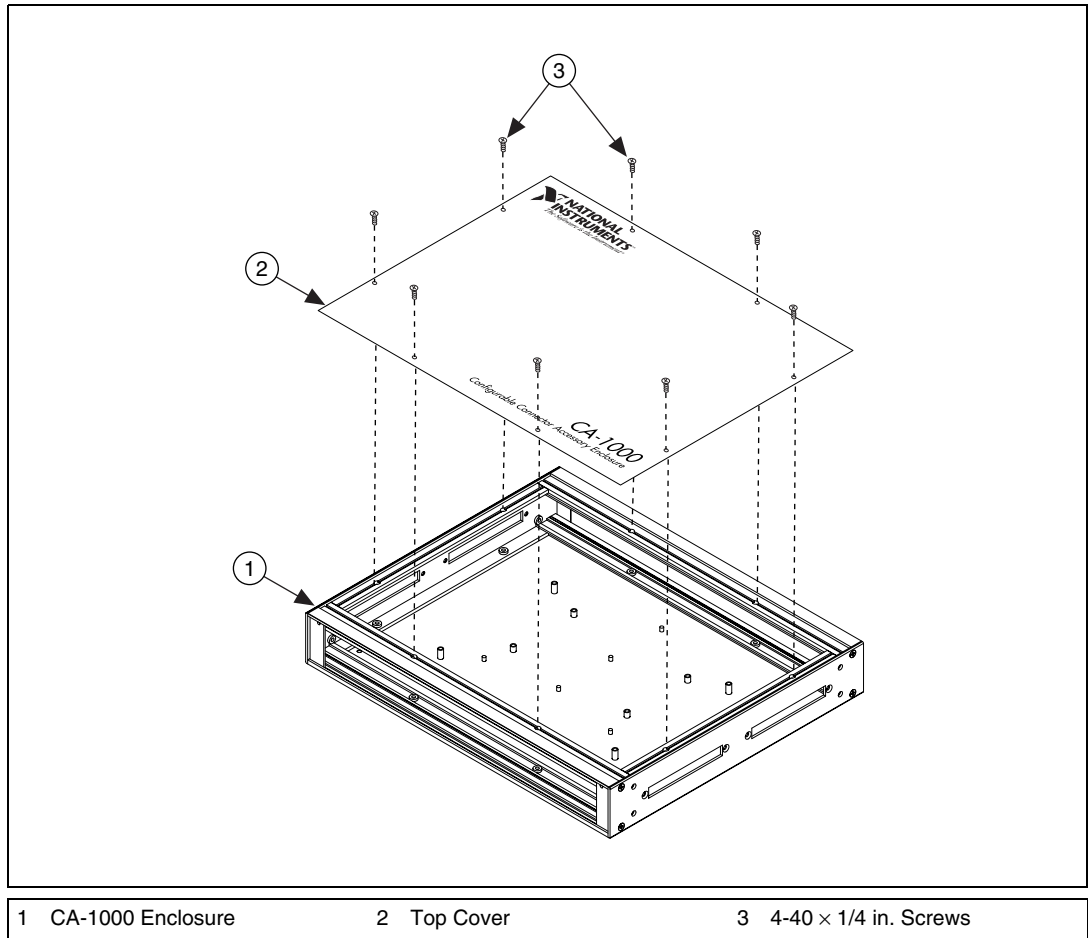

Figure 2. Opening the CA-1000 Enclosure

Internal Accessory

You can easily install many National Instruments DAQ accessories in the CA-1000 enclosure.

Refer to Figure 3 and use the following steps to install the SC-2040, SC-2042-RTD, SC-2043-SG, SC-2070, SC-2071, or SC-2072 into the CA-1000 enclosure:

1. Remove the standoffs originally supplied on the SC-204x or SC-207x internal accessory.
2. Position the SC-204x or SC-207x internal accessory on the pre-installed standoffs of the CA-1000.
3. Install and tighten the four 4-40 panhead screws included with your SC-204x or SC-207x internal accessory.



Note You can also mount the accessory rotated 180° from the position shown in Figure 3.

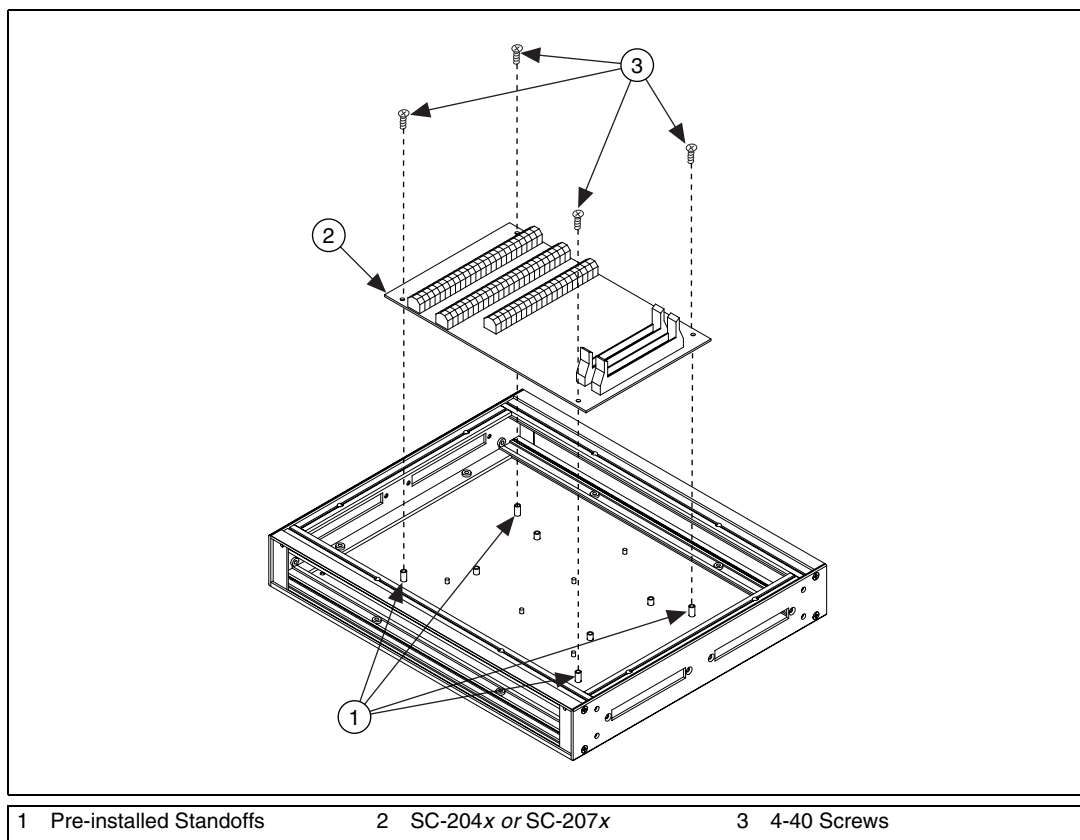

Figure 3. Installing the SC-204x or SC-207x

Refer to Figure 4 and use the following steps to install the CB-50LP into the CA-1000 enclosure:

1. Remove the standoffs originally supplied on the CB-50LP internal accessory.
2. Position the CB-50LP internal accessory on the pre-installed standoffs of the CA-1000.
3. Insert and tighten the four 4-40 panhead mounting screws included with your CB-50LP internal accessory.



Note You can mount the accessory rotated 180° from the position shown in Figure 4 to correspond with your application needs.

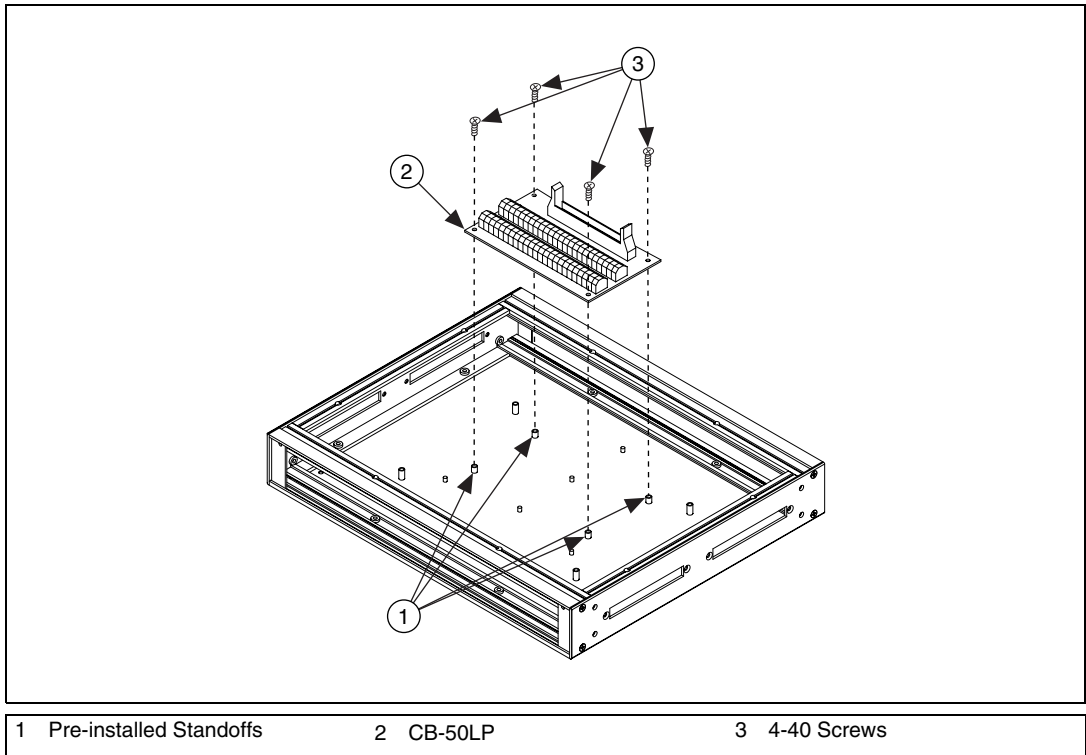

Figure 4. Installing the CB-50LP

You can install one or two CB-68LPR accessories in one or two of four positions (A, B, C, and D in Figure 5) in the CA-1000 enclosure.



Note You can mount a single CB-68LPR internal accessory in position A, B, C, or D. You cannot install a pair of CB-68LPR internal accessories in both positions A and D or in both positions B and C.

Refer to Figure 5 and use the following steps to install the CB-68LPR into the CA-1000 enclosure:

1. Remove the four standoffs originally supplied on the CB-68LPR internal accessory.
2. Tighten the 1/2 in. long nylon 4-40 female-to-female standoffs on the pre-installed threaded studs as indicated.



Note See [Internal Cable Assembly](#) in this guide and Figure 7 for details on installing the 68-pin filler panel.

3. Install the 68-pin filler panel on the 68-pin connector with two M2.5 jackscrew screws provided with the CB-68LPR.



Note Do not use the washers for this installation.

4. Install the 68-pin filler panel in the enclosure with two 4-40 × 3/16 in. flathead Phillips-head screws provided with the CA-1000. This positions the CB-68LPR over two of the female-to-female standoffs.
5. Insert and tighten the two 4-40 panhead mounting screws provided with the CB-68LPR.



Note If you install two CB-68LPRs, you need to use two 68-pin filler panels.

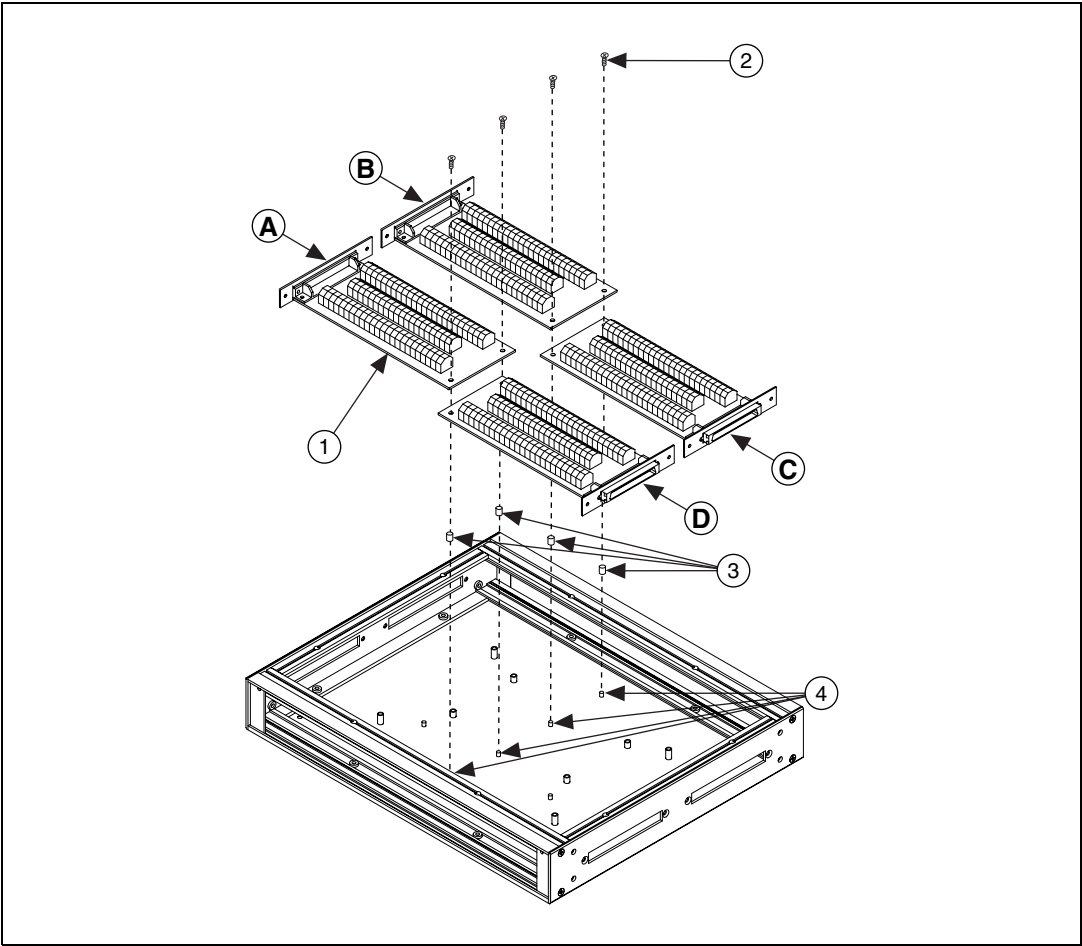

- | | | | | | | | |
|---|----------|---|-------------|---|-----------|---|------------------------------|
| 1 | CB-68LPR | 2 | 4-40 Screws | 3 | Standoffs | 4 | Pre-installed Threaded Studs |
|---|----------|---|-------------|---|-----------|---|------------------------------|

Figure 5. Installing the CB-68LPR

Refer to Figure 6 and use the following steps to install the SCB-68 into the CA-1000 enclosure:

1. Tighten the 1/2 in. long nylon 4-40 female-to-female standoffs on the pre-installed threaded studs as indicated.
2. Install the 68-pin filler panel on the 68-pin connector with two M2.5 jackscrew screws provided with the SCB-68.
3. Install the 68-pin filler panel in the enclosure with two 4-40 × 3/16 in. flathead Phillips-head screws provided with the CA-1000. This positions the SCB-68 over two of the female-to-female standoffs.



Note See *Internal Cable Assembly* later in this guide and Figure 7 for details on installing the 68-pin filler panel.

4. Insert and tighten the two 4-40 panhead mounting screws provided with the SCB-68.

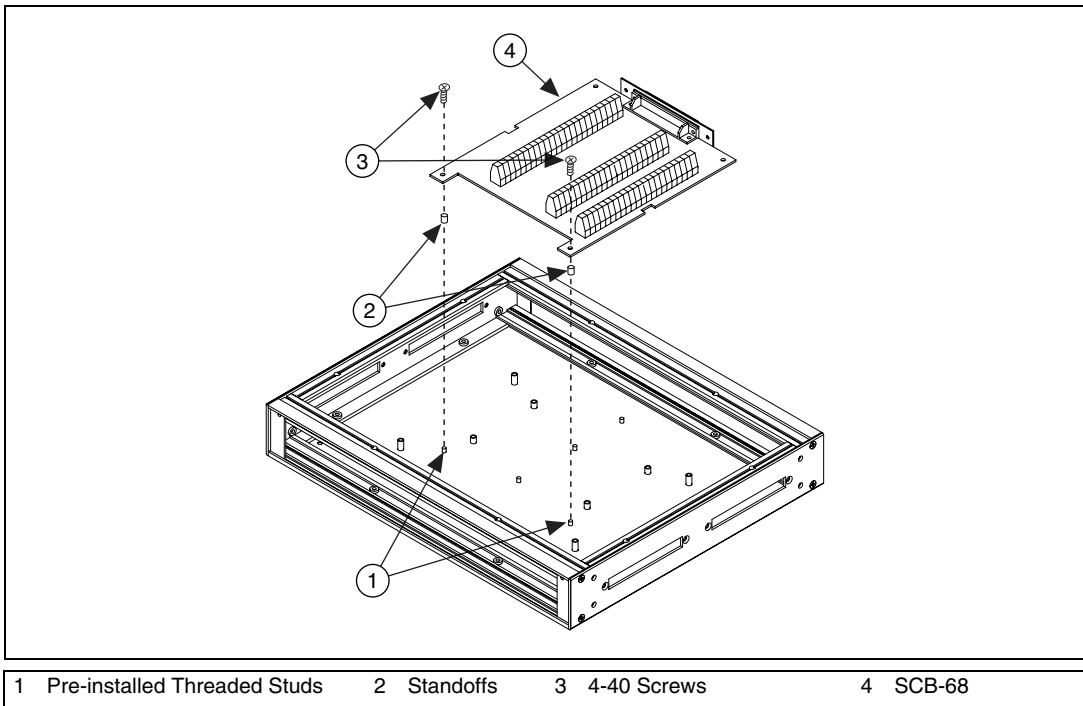

Figure 6. Installing the SCB-68

Internal Cable Assembly

When connecting a 68-pin external cable to a 50-pin CA-1000 accessory card, you must use an R68M-50F MIO Bulkhead Ribbon Cable within the enclosure. Refer to Figure 7 and use the following steps to install the R68M-50F MIO Bulkhead Ribbon Cable into the enclosure:

1. Choose one of the available openings for the 68-pin filler panel according to your application.
2. Place the 68-pin filler panel inside the enclosure.
3. Secure the 68-pin filler panel to the enclosure using two 4-40 × 3/16 in. Phillips-head screws.
4. Secure the 68M-50F MIO Bulkhead Cable Adapter to the 68-pin filler panel using two M2.5 jackscrew screws that are provided with the adapter.
5. Attach the 50-pin female connector of the ribbon cable to the 50-pin accessory.
6. Attach the male connector of the ribbon cable to the 68M-50F MIO Bulkhead Cable Adapter.
7. Secure blank filler panels in any remaining open slots using two 4-40 × 3/16 in. flathead screws per filler panel.



Note When you connect a 50-pin external cable to a 50-pin CA-1000 accessory, you must remove the 68-pin filler panel and the 68M-50F MIO Bulkhead Cable Adapter. This allows you to attach the male end of the R50M-50F ribbon cable to the wall of the CA-1000 enclosure with two 4-40 × 3/16 in. screws.

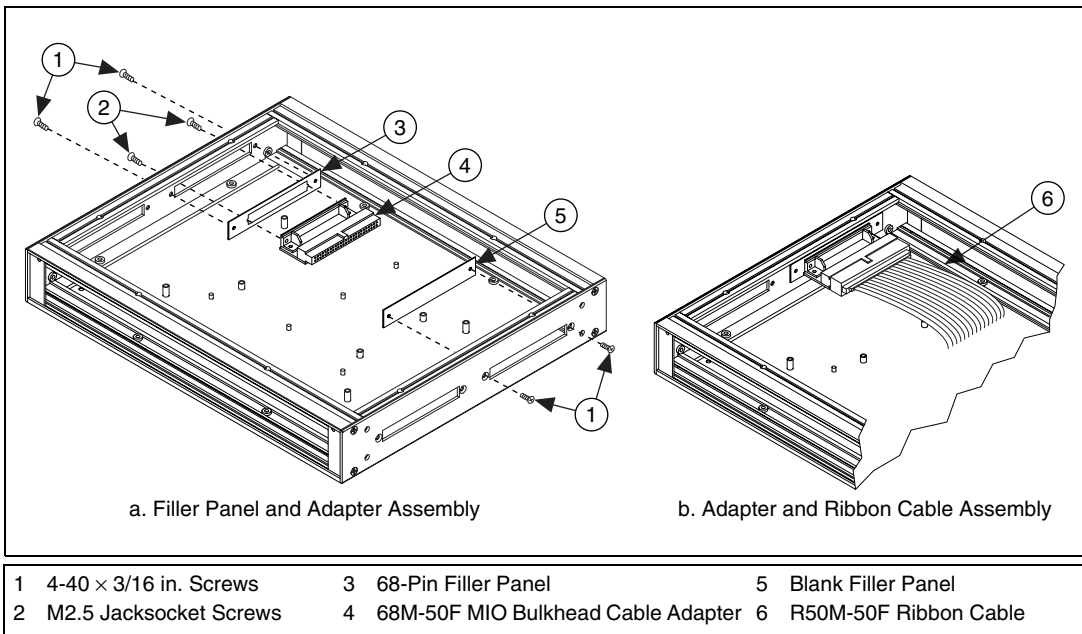

Figure 7. Installing the 68M-50F MIO Bulkhead Cable

I/O Panelettes

Use the user-configurable I/O panelettes to specify the type and combinations of I/O connectivity for your application. The interchangeable I/O panelettes have standard prewired I/O connectors. You can install I/O panelettes on the front and/or rear of the CA-1000 enclosure.

You can install up to 18 single-width I/O panelettes, nine in the front and nine in the rear, in the CA-1000 enclosure. You can mix all types of I/O panelettes to produce custom I/O combinations.



Note The strain-relief and 9-pin D-sub I/O panelettes require two panelette spaces. The dual 9-pin D-sub I/O panelette requires three panelette spaces.

Each thermocouple and BNC I/O panelette accommodates two connectors. Use the strain-relief I/O panelettes to connect large numbers of wires directly to your internal accessory. You can machine the blank I/O panelettes to make custom I/O panelettes to suit your application. Use the preconfigured I/O panelettes to quickly connect and disconnect standard connectors.

Refer to Figure 8 and use the following steps to install any of the I/O panelettes:

1. Choose one of the I/O panelettes to install.
2. Place the lower edge of the I/O panelette in the groove at the bottom of the enclosure opening.
3. Tilt the I/O panelette top back into the enclosure.
4. Secure the I/O panelette with either one, two, or three of the M2.5 × 6 panhead screws (depending on the type of I/O panelette) that are included with the panelette.
5. Repeat steps 1 through 4 until you have installed all your functional I/O panelettes.
6. Install a blank I/O panelette in any unused panelette opening.



Note You must remove the pre-installed rear panel prior to installing any I/O panelettes on the rear of the CA-1000.

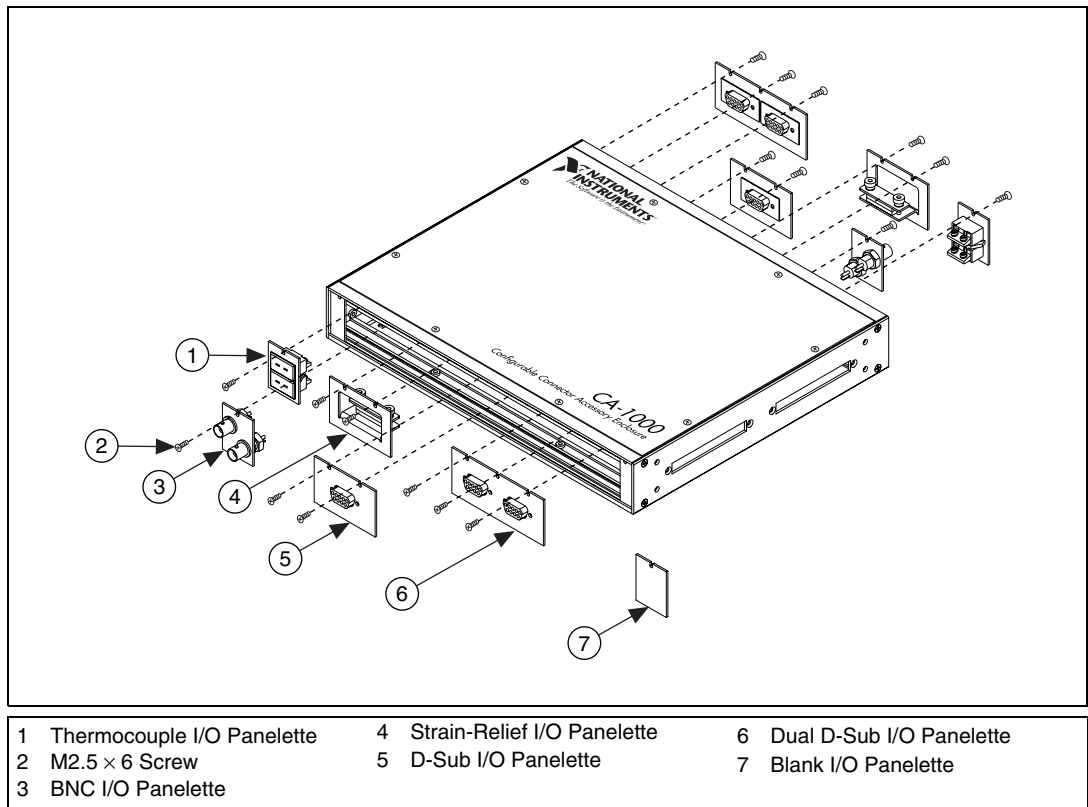

Figure 8. Installing an I/O Panelette

I/O Panelette Labels

Each CA-1000 enclosure comes with a sheet of labels for you to label your I/O panelettes. The label sheet has both preprinted and blank labels. You can customize the blank labels to suit your application. Figure 9 shows the placement of the I/O panelette label. You can use two labels on single-width I/O panelettes and three or more labels on wider panelettes.

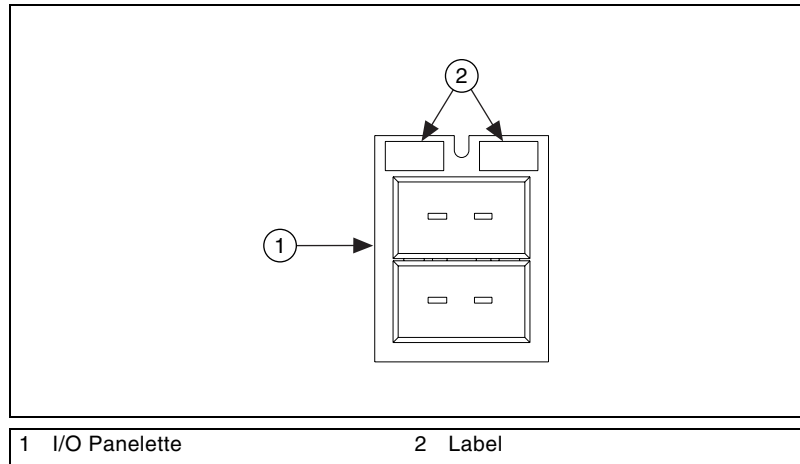

Figure 9. Installing an I/O Panelette Label

Rubber Feet

Each CA-1000 enclosure comes with a set of four rubber feet and four screws as shown in Figure 10. Use the following steps to install the rubber feet:

1. Place a 4-40 panhead shoulder screw with a 0.08 in. shoulder length and a 0.125 in. thread length through the center of each rubber foot.
2. Screw all four rubber feet to the bottom of the CA-1000 enclosure.

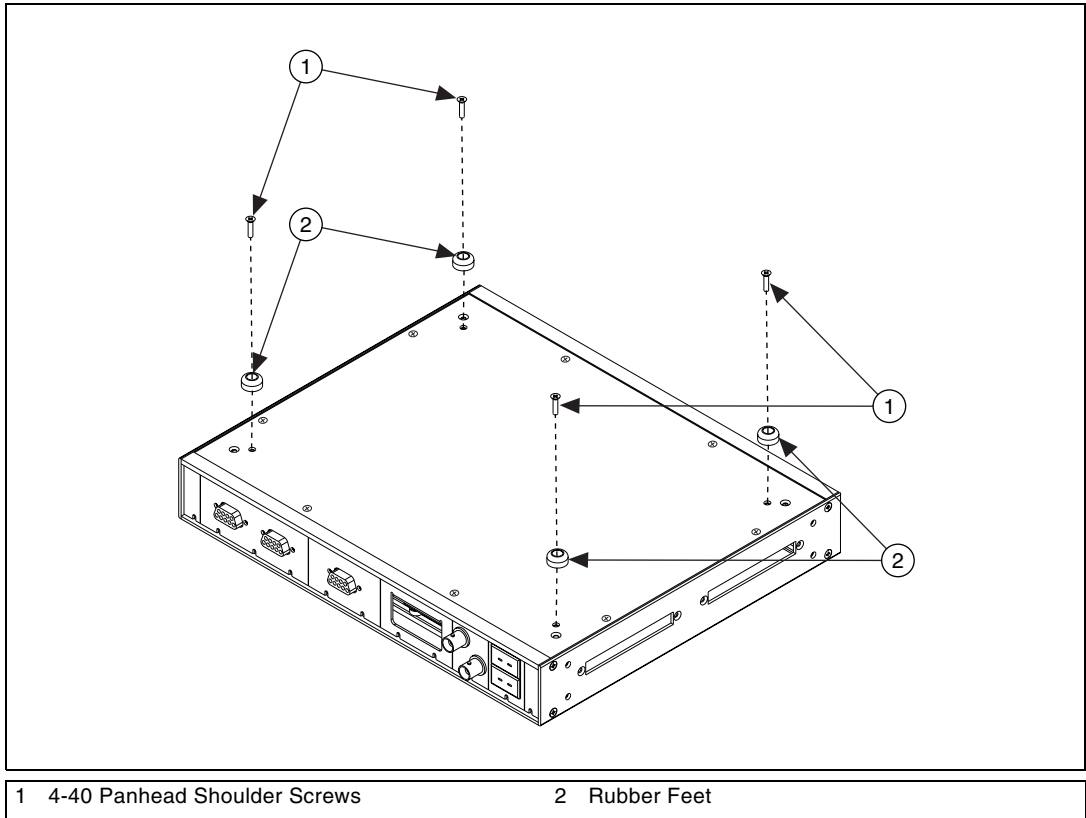

Figure 10. Installing Rubber Feet

Internal Accessory Signal

Insert the wires from your I/O panelettes into the appropriate screw terminals on your internal accessory according to the needs of your application. Figure 11 shows a typical installation.

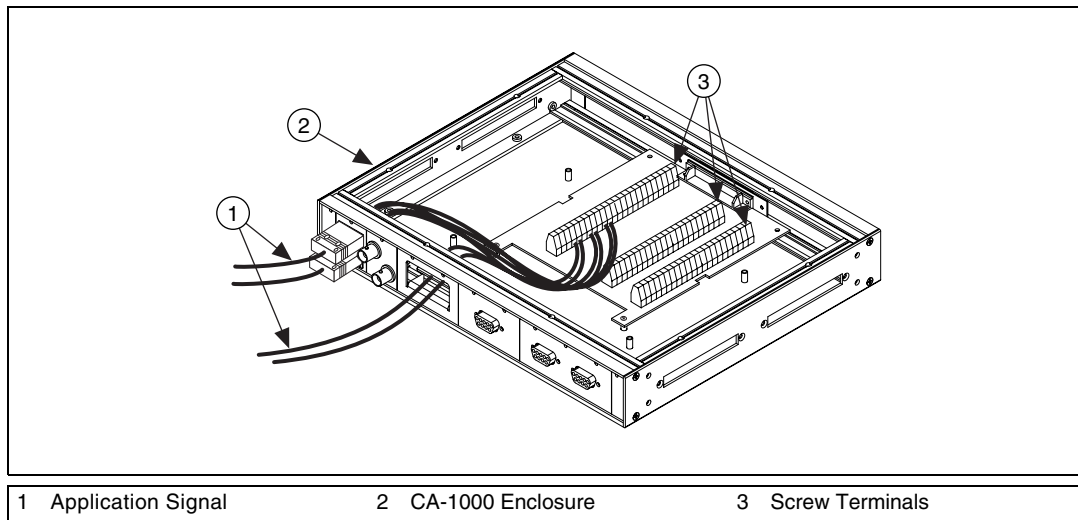

Figure 11. Installing I/O Wiring

External Cables

You can connect a variety of standard National Instruments cable assemblies to the CA-1000 enclosure. The type of cable you attach depends on your application, your internal accessory, and your cable adapters.

You can choose from five locations for external cable connection on the CA-1000. One of these locations will align with the PCMCIA slots on most laptop computers. Refer to Figure 12 and use the following steps to install your external cable assembly:

1. Attach one end of the external cable to the enclosure.
2. Attach the other end of the external cable to your DAQ device.

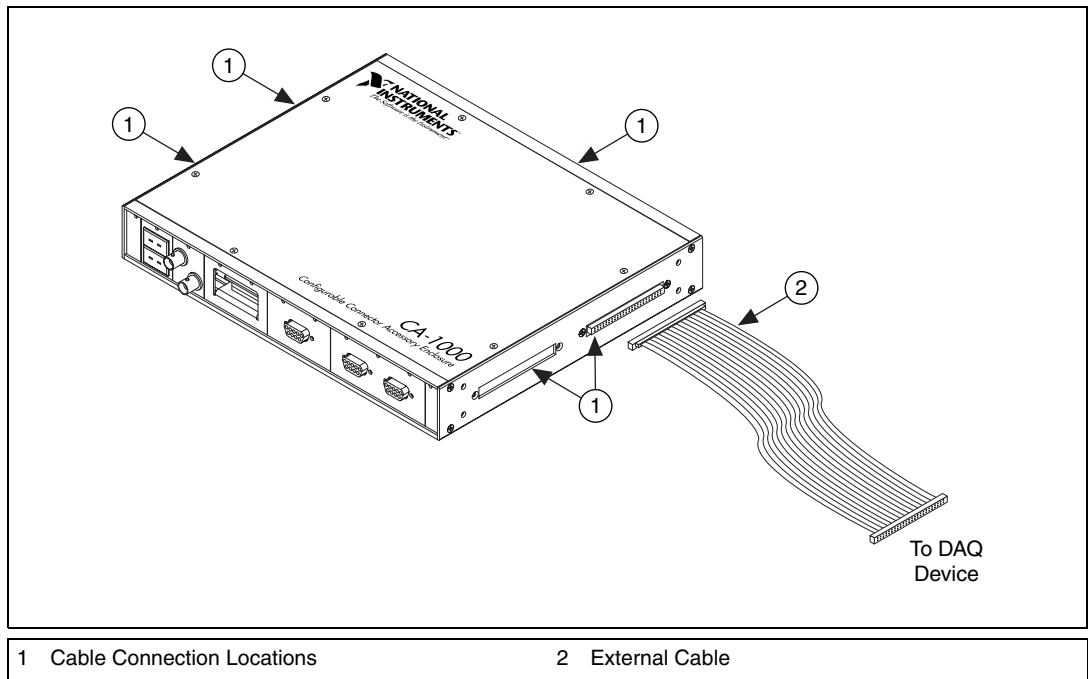

Figure 12. Installing External Cable Assemblies

Options

You can use your CA-1000 enclosure in a standard 19 in. rack-mount configuration by installing the optional CA-1000 rack-mount kit or in a desktop stacking configuration by installing the optional CA-1000 stack-mount kit.

Refer to Figure 13 and use the following steps to install the CA-1000 rack-mount kit on your CA-1000 enclosure:

1. Attach the rack-mount bracket to one end of the enclosure with two 4-40 × 1/4 in. screws provided with the rack-mount kit.
2. Attach the rack-mount bracket to the other end of the enclosure with two 4-40 × 1/4 in. screws provided with the rack-mount kit.



Note You must remove the rubber feet from the enclosure in rack-mount applications.

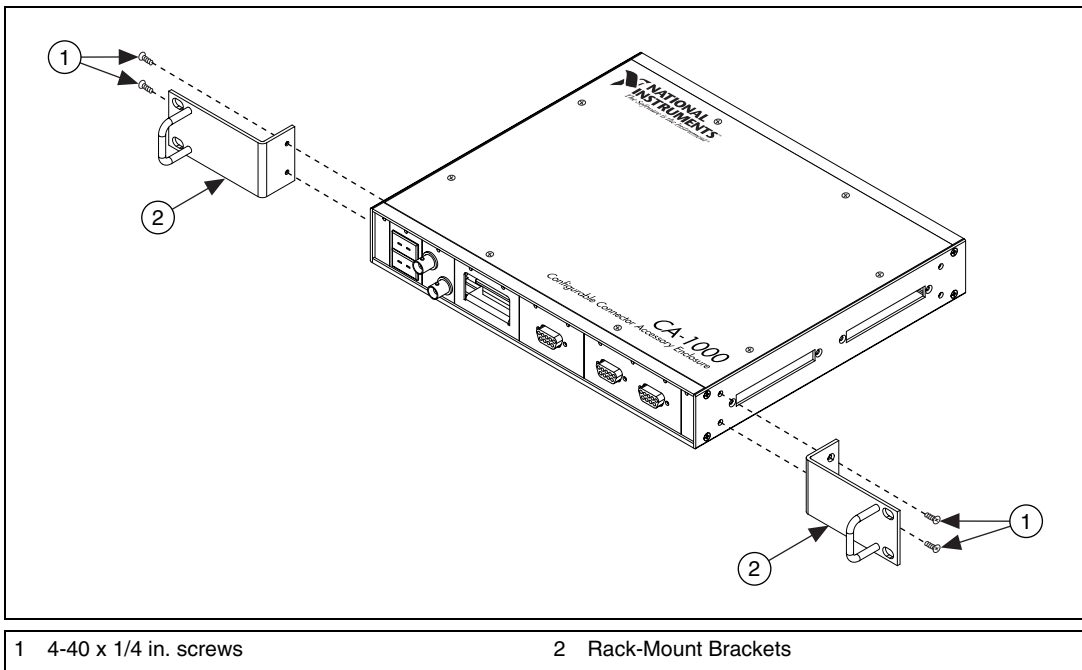

Figure 13. CA-1000 Rack-Mount Kit

Refer to Figure 14 and use the following steps to install the CA-1000 stack-mount kit on your CA-1000 enclosure:

1. Attach the stack-mount brackets to both ends of the lower enclosure with the 4-40 × 1/4 in. flathead screws provided with the stack-mount kit.
2. Place the upper enclosure on top of the lower enclosure.
3. Attach the stack-mount brackets to both ends of the upper enclosure with the 4-40 × 1/4 in. flathead screws provided with the stack-mount kit.



Note You must remove the rubber feet from all but the bottom enclosure before stacking them.

You can stack additional enclosures by using additional stack-mount kits.

The stack-mount kit handles can be removed, if necessary, by removing two screws.

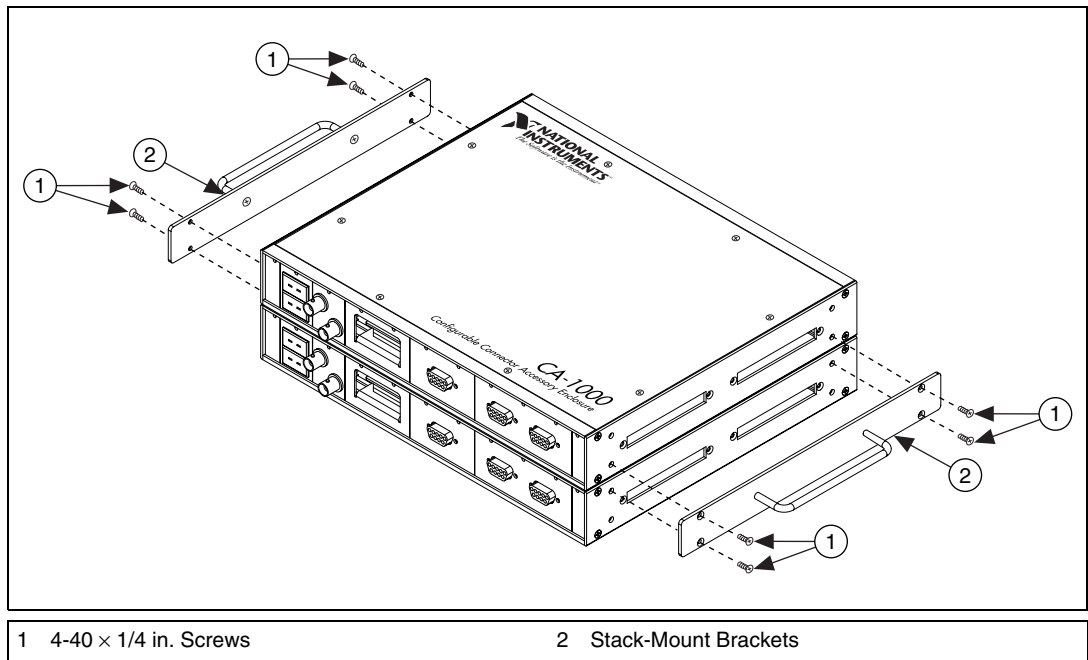

Figure 14. CA-1000 Stack-Mount Kit

Specifications

I/O connectors.....	User defined
Power requirements	User defined, depends on internal accessory
Current excitation	User defined, depends on internal accessory
Operating environment	User defined, depends on internal accessory
Physical dimensions	30.63 by 25.40 by 4.39 cm (12.06 by 10.00 by 1.73 in.)

